

DEPA[®]

brands you trust.



DEPA[®] Air-Operated Double Diaphragm Pumps

CRANE[®]

Crane ChemPharma & Energy

www.cranecpe.com

About DEPA®



Established in 1961, in Düsseldorf, Germany, Crane Process Flow Technologies GmbH, is a manufacturer and supplier with many years of knowledge and experience for pneumatic actuators (REVO), peristaltic pumps (ELRO) and positive displacement AODD pumps (DEPA). The remarkable features of our products are its great variety of materials and models for safe operations.

Furthermore, we provide customized solutions for specific and demanding industrial applications.

DEPA® Air-Operated Double Diaphragm (AODD) pumps are designed, manufactured and assembled since 1968 in Düsseldorf, Germany. The pumps have earned industry recognition for premium quality and innovative design.

Our products & Solutions

- Air Operated Double Diaphragm Pumps
- Original Spare Parts
- Spare Part Kits
- Global Pump Service



Key Features

Our Uniquely-Built Pumps Offer...

- ① Compact design requires fewer components, resulting in lower maintenance and downtime
- ② Interchangeable modular design allows fewer spare parts inventories
- ③ Special applications can be accommodated by combining our housing and elastomer materials



Applications Air Operated Diaphragm Pumps

Series M



Main Applications

- Automobile
- Chemical
- Ceramic and Porcelain
- Mining, Building
- Paint and Varnish
- Wastewater

Housing Material

Aluminium

Multi-purpose housing material that is lightweight with versatile properties suitable for transfer of alcohols, paints, petrols, and oils.

Cast Iron

Robust, ductile material (spheroidal graphite) with resilient mechanical characteristics. Applicable for abrasive materials, alcohols, petrols, and oils.

Stainless Steel

Austenitic steel, cast, with a high level of chemical and corrosion resistance. Suitable for environments containing acids, solvents, and caustic media.

Series P



Main Applications

- Chemical
- Galvanic and Coating
- Paint and Varnish
- Pulp and Paper
- Pharmaceutical
- Plant and Mechanical Engineering
- Power Stations and Waste Disposal Technology

Housing Material

Polypropylene

Excellent chemical and corrosive resistance. Suitable for acids, solvents, and caustic products, also available in electrically conductive variants.

PTFE

Thermoplastic material with superior chemical and corrosive resistance properties. For undiluted heavy acids and caustic media, also available in electrically conductive material.

Series L



Main Applications

- Beverage
- Biotechnology
- Chemical
- Cosmetic
- Dairies
- Food
- Medical Applications
- Pharmaceutical

Housing Material

Polished Stainless Steel

Austenitic steel, forged, with a high level of chemical and corrosion resistance. Suitable for food processing and also for environments containing acids and lye.

* Varies depending of the inside materials

Applications

Air Operated Diaphragm Pumps

Chemical

This selection of available housing and elastomer materials make our pumps adaptable for most highly aggressive or corrosive media. DEPA® pumps' outstanding chemical resistance and robust design contribute to a reliable and safe operation.

Pharmaceutical and Cosmetic

Pharmaceutical and Cosmetic process applications call for demanding hygienic standards and efficient "cleanability" of system components. DEPA® pumps accommodate these requirements with their design and polished surfaces, CIP (cleaning in place) & SIP (sterilization in place).



Food

DEPA® pumps were designed with an unimpeded flow-path, providing smooth transfer of product, which generates minimal shear effect even with large solid content.

Paint and Varnish

Paints and varnish production utilizes unique applications. Two of these applications are dosing of chemicals and mixing of paints. A commonly found process—transfer of solvents—can create an explosion-prone atmosphere. Our DEPA® pumps operate safely under these conditions, and comes with full ATEX certification for your peace of mind.

Tanks/Cisterns - Evacuation (or transfer between vessels)

DEPA® pumps operate effectively in applications such as emptying of mobile and stationary tanks. Their high flow rate speeds up this process. The media transferred (pumped out) can vary from solvents and acids to alkali or other products.



Interchangeable Design Air Operated Diaphragm Pumps

A key design concept of our DEPA® Air-Operated Double Diaphragm Pumps is a modular, compact design. Fewer parts lead to pump efficiency thereby reducing downtime and parts inventories.

Our pumps can easily be modified to switch from one application to another simply by changing the diaphragms, balls, and seats.

Note: The illustration shows the typical arrangement of the clampband version DL. The DH version is referred to as the flanged design as the pump chambers are bolted to the centre block.

Housing Material Options

FA	Aluminium
CA	Nodular Cast Iron
CX	Nodular Cast Iron
SA	Cast Stainless Steel 316 L
SS	Cast Stainless Steel 316 L
SX	Cast Stainless Steel 316 L
SF	Cast Stainless Steel 316 L Electro-Polished
SLV	Stainless Steel 304 Polished
SUV	Stainless Steel 316 L Polished
UEV	Stainless Steel 316 L Polished
PP	Polypropylene
PL	Polypropylene Electrically conductive
PM	Polypropylene Injection Molded
PV	PVDF
TP	PTFE
TPL	PTFE Electrically conductive

Center Block Material Options

FA, SA, CA	Aluminium
CX	Bronze
SLV, SUV, UEV, SFS, SS	Stainless Steel
SF	Aluminium, Nickel-Coated,
PL, TPL	Polypropylene, Electrically conductive
PP, PM, TP	Polypropylene

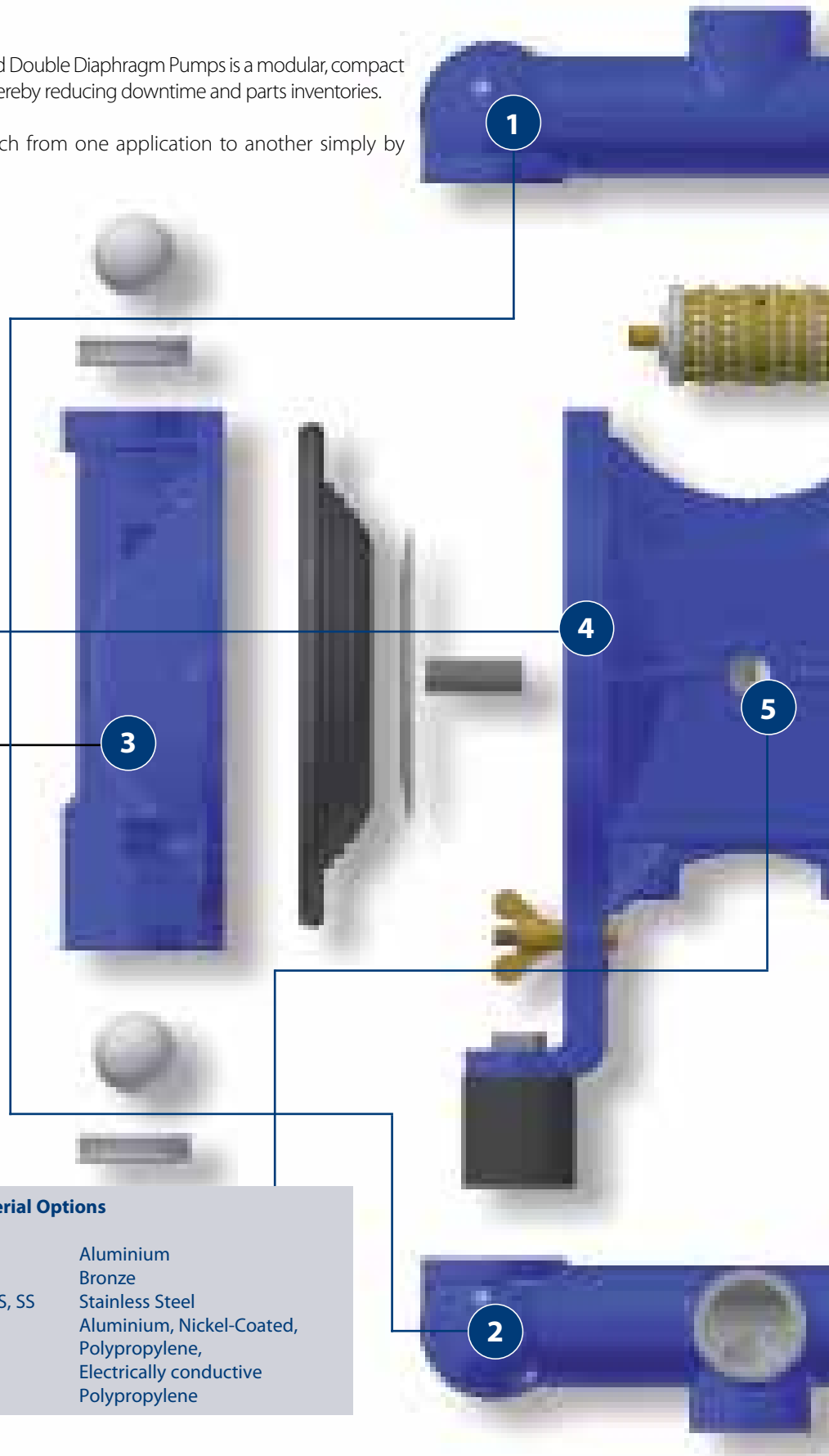

Interchangeable Design Air Operated Diaphragm Pumps

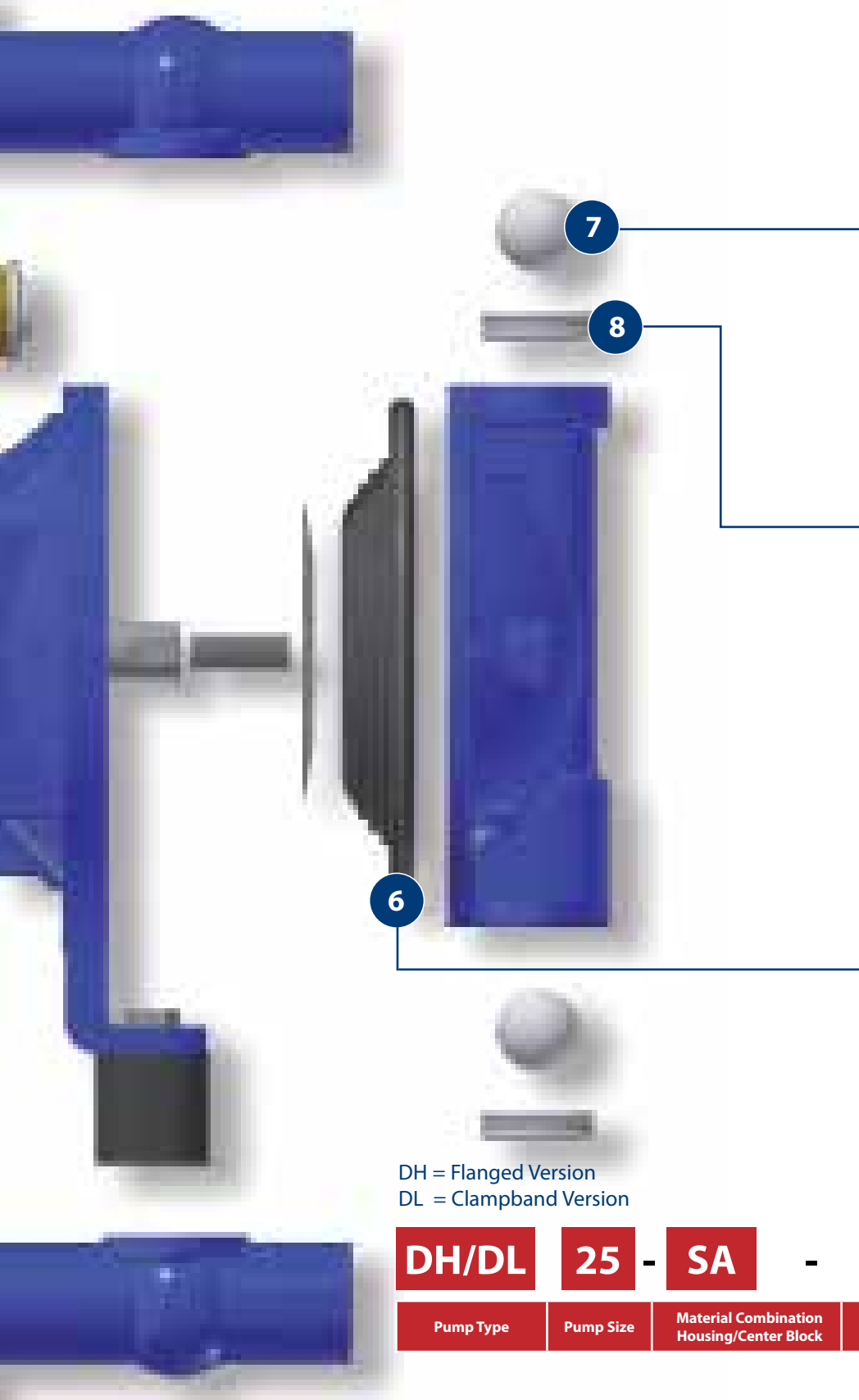

Valve Balls Material Options

- B NRS
- E EPDM
- F FKM
- G EPDM Grey
- N NBR
- R Stainless Steel
- T PTFE
- V NRS/Steel Core
- W EPDM/Steel Core
- X EPDM Grey/Steel Core
- Y NBR/Steel Core
- Z PTFE/Steel Core

Valve Seats Material Options

- B NRS
- E EPDM
- F FKM
- G EPDM Grey
- H Stainless Steel-only DB
- N NBR
- R Stainless Steel
- T PTFE

Diaphragms Material Options

- 5 CSD nopped E4° NRS
- 2 CSD nopped E4° EPDM
- 4 CSD nopped E4° FKM*
- 3 CSD nopped E4° EPDM Grey
- 1 CSD nopped E4° NBR
- P PTFE (DH, Series L only)
- U EPDM Grey (DH, Series L only)
- X CSD nopped E4° PTFE
Compound Diaphragm
electrically conductive
- Y CSD nopped E4° PTFE
Compound Diaphragm with
Stainless Steel Insert
- Z CSD nopped E4° PTFE
Compound Diaphragm with
Aluminium Insert

*a diaphragm based on Viton™ fluoroelastomer, Viton™ is a registered trademark of The Chemours Company

DH = Flanged Version
DL = Clampband Version

DH/DL

25

SA

2

E

T

Pump Type	Pump Size	Material Combination Housing/Center Block	Diaphragms	Valve Seat	Valve Balls
-----------	-----------	----------------------------------------------	------------	------------	-------------

Air Control

Air Valve

In applications distributed across the globe, DEPA® Air-Operated Double Diaphragm Pumps are subjected to impressive ranges of operating temperatures, pressure fluctuations, full load, and intermittent operating conditions.

This often places severe demands on the air valve responsible for the distribution of air in the individual chambers, thereby regulating the operation of the pump.

Internal Air Valve

- Reezing virtually eliminated
- No dead centre
- Low maintenance, oil-free operation
- Suitable for outside applications
- Economical
- Not affected by minor contamination of compressed air
- Durable
- Reliable

In order to meet the emerging requirements of industry, DEPA® engineers conduct ongoing intensive research and development work to maintain “state-of-the-art” status for our products. Functional safety and low maintenance requirements have always been among our major guiding design principles.

DEPA® Air-Operated Double Diaphragm Pumps can be equipped with either internal or external air control units.



Internal Air Valve
made in nickel

Internal Air Valve
made in stainless steel



External Air Valve

- Quickly replaceable
- Low start-up pressure
- No dead centre
- Low maintenance, oil-free operation
- Economical, suitable for all pumps
- Simple handling
- Durable
- Air saving due to leakage rate

An innovative and robust DEPA® AirSave design increases the energy efficiency and service life of the pump. It delivers outstanding performance and operates at a low start-up pressure with hardly any leakage.

Shorter maintenance downtime and reduced number of spare parts decreases the operating costs.

The AirSave System is diversified for a broad range of applications. It is compatible with DEPA® Type DL-Series Polypropylene (PM, PP & PL) pumps, Sizes 15/25/40 and with Type DH-Series (FA) and Stainless Steel (SA & SS) pumps, Sizes 15/25/40. ATEX compliant if in combination with ATEX conform DEPA® pumps.

Materials and Selection

DEPA® Closed Surface Diaphragms Series nopped E4®

The new DEPA® CLOSED SURFACE DIAPHRAGM SERIES is designed and manufactured in-house. The diaphragms are available in the sizes 15 (1½"), 25 (1"), 40 (1 ½"), 50 (2") & 80 (3") and offers the following key features and benefits:

- ① **Extended Lifetime**
- ② **Eliminates Leaks**
- ③ **Ease of Maintenance**
- ④ **Easy to Clean**



Nopped E4® EPDM Grey

Features: Pale elastomer rubber material with good elastic properties & viable chemical resistance for acidic & caustic products; environments with solvents & alcohols are common applications.

Applications: Food, pharma & beverage
Temperature: -25°C to +90°C



Nopped E4® PTFE Compound

Features: PTFE diaphragm with EPDM back up; the high chemical resistance appropriate for heavy acids & caustic products.

Applications: All chemical (& transfer of aggressive chemicals, also in "EX-areas")
Temperature: -10°C to +130°C

Applied Guidelines in combination with the pumps

- Machinery Directive 2006/42/EC
- Eurasian Conformity
- For the EPDM Grey diaphragm & PTFE Compound diaphragm
 - FDA Conformity
 - 1935/2004/EC & 10/2011/EU
 - Bisphenol-A and Phthalates free
 - BfR Recommendation XXI (category 3)
- The diaphragms are ATEX compliant in accordance with directive 2014/34/EU in combination with the pump



Nopped E4® EPDM

Features: Elastomer rubber with sound elastic properties; good chemical resistance for acidic & caustic media; frequently used with solvents & alcohols.

Applications: Misc. chemical & industrial
Temperature: -25°C to +105 °C



Nopped E4® FKM*

Features: Elastomer rubber with good chemical resistance & applicable for hydrocarbons, acidic, & caustic media. Withstands elevated temperatures.

Applications: Misc. chemical & industrial
Temperature: -5°C to +120°C



Nopped E4® NBR

Features: Multi-purpose diaphragm of nitrile rubber for oily or greasy service; suitable for diverse hydrocarbons, mineral oils, grease & fuels.

Applications: Chemical & industrial
Temperature: -15°C to +90°C



Nopped E4® NRS

Features: Versatile multi-purpose natural rubber elastomer with good wear characteristics & elasticity, especially well-suited for abrasive products & highly diluted caustic & acidic media, & water.

Applications: Applications with solid content, & heavy duty applications
Temperature: -15°C to +70°C

Metallic Pumps, Series M Type DH Overview



DEPA DH® Next Generation Air Operated Double Diaphragm Pumps for industrial applications are made of cast aluminum (FA) and cast stainless steel (SA&SS).

The flexible, multiport manifold can be customized to plant specifications and provides up to 25 connection for the cast aluminum pumps (FA) and up to 16 options for the cast stainless steel pumps (SA & SS) to accommodate various operational requirements.

DEPA DH® pumps feature cast feet integrated in the center block housing that enable maintenance in place (MIP). This unique design can reduce downtime by up to 25%* and optimizes assembly and disassembly through a 30%* reduction in required parts. Rubber feet can be easily mounted with a slotted locating hole in the center block housing.

An innovative flange design with “block-mounted” pump- and air chambers provides a safe and well-defined diaphragm clamping mechanism. The diaphragm is fixed to specifications to provide consistent lifetime wear and tear and eliminate overstretching of the pump.

Our high-efficiency flow design with Free Flow Path technology reduces unused volume with an optimized chamber for specific diaphragm design and dimensions. This technology can increase the scope of applications, accommodate particle sizes up to 25mm (DH80-FA, for DH80-SA & SS the max solid size is 18 mm), and reduce the total cost of ownership through enhanced efficiency.

Pumps can be supplied with our DEPA® AirSave-System, leakage monitoring system and stroke counter sensor.

Type	DH 15 (½")	DH 25 (1")	DH 40 (1 ½")	DH 50 (2")	DH 80 (3")
FA - Aluminium	●	●	●	●	●
SA - Cast Stainless Steel (316L) with Aluminium Center Block	●	●	●	●	●
SS - Cast Stainless Steel (316L)	●	●	●	●	●

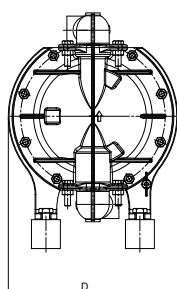
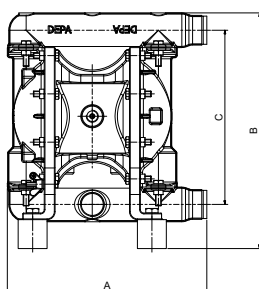
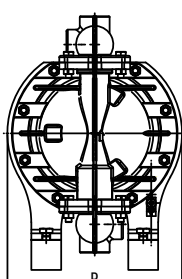
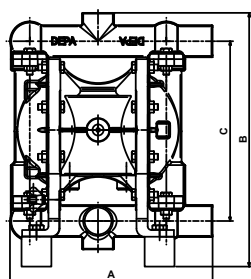

Type	Dimensions mm			
	A	B	C	D
DH15-FA	207	266	180	174 (186) ¹⁾
DH25-FA	272	340	241	234
DH40-FA	370	437	307	266
DH50-FA	502	522	414	351
DH80-FA	568	717	522	434

1) External DEPA® AirSave System

Type	Dimensions mm			
	A	B	C	D
DH15-SS	211	251	180	174 (186) ¹⁾
DH25-SS	276	326	241	234
DH40-SS	380	421	307	266
DH50-SS	508	546	414	351
DH80-SS	629	686	522	434

1) External DEPA® AirSave System

Metallic Pumps, Series M Type DL Overview



DEPA® Air-Operated Double Diaphragm Pumps made of cast metal have proven themselves over decades in various industrial applications. The myriad of established applications across the globe include installations on ships, at well-known ceramics manufacturers, in spray painting systems (in the

automobile industry), and in mining operations, among countless others.

The sturdy cast metal construction provides high resistance to abrasive media and a low flow resistance, owing to its polished surface. They are available in a wide selection of temperature ratings, and offer excellent corrosion resistance and a long product life.

The compact design makes the pumps easy to transport and they can be used as mobile or stationary units.

Our pumps were designed for ease of maintenance in order to minimise downtime, and they can be easily disassembled without any special tools.

Their modular design enables flexibility and restricts the need for large spare parts inventories. DEPA® cast metal pumps can be fitted with a comprehensive assortment of accessories to match the requirements of applications. This flexibility is further enhanced by the availability of various housing and elastomer materials – extending the range of applications for which our pumps can be used.

Type	DL 15 (½")	DL 25 (1")	DL 40 (1 ½")	DL 50 (2")	DL 80 (3")
CA - Nodular Cast Iron	-	●	●	●	●
CX - Nodular Cast Iron / Bronze	-	●	●	●	●
HS - Hasteloy / Stainless Steel	●	●	●	●	●

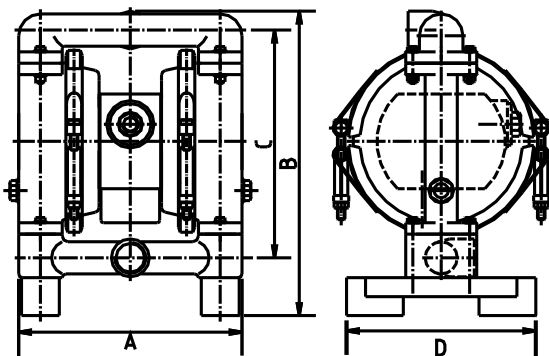

Type	Dimensions mm			
	A	B	C	D
DL 15	190	225	180	122
DL 25	236	322	241	200
DL 40	310	407	306	255
DL 50	412	540	415	340
DL 80	510	680	522	420

Non-Metallic Pumps Series P Overview



Series P made of mechanically manufactured or specially injection moulded plastic parts was designed for problem free pumping of corrosive and abrasive products in galvanic applications, in the chemical industry, and in mechanical engineering.

Mechanically stable metals do not necessarily possess the required chemical resistance needed for certain corrosive media. For applications needing such resistance, we developed our DEPA® Series P air-operated double diaphragm pump versions that are made of plastic materials.

The Series P operating pressure tolerances compare with cast metal pumps, handling pressures up to 7 bar.

Computer-aided injection moulding methods deliver uniform, high quality surface finishes, minimizing flow loss while providing excellent abrasion resistance. High mechanical stability is achieved in a compact construction.

Our broad selection of construction materials allows the Series P pumps to be used in diverse applications. Internally and externally mounted air control valves are available, and our customers can choose from ANSI, DIN, and JIS flanges and threaded connections. To ensure suitability for a variety of media, wetted parts are available in numerous optional materials.

Type DL	DL 15 (½")	DL 25 (1")	DL 40 (1 ½")	DL 50 (2")	DL 80 (3")
PM - Polypropylene, Injection Moulded	●	●	●	-	-
PP - Polypropylene	●	●	●	●	●
PL - Polypropylene electrically conductive	●	●	●	●	-
Type DH	DH 15 (½")	DH 25 (1")	DH 40 (1 ½")	DH 50 (2")	DH 80 (3")
TP - PTFE	●	●	●	●	-
TPL - PTFE electrically conductive	●	●	●	●	-

Type DL

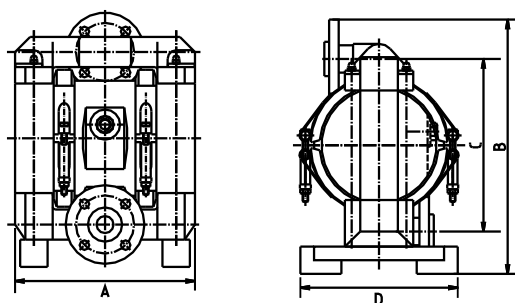

Type	Dimensions mm			
	A	B	C	D
DL 15	212	293	185	195
DL 25	263	372	252	230
DL 40	353	489	334	255
DL 50	450	622	448	340
DL 80	558	785	578	420

Type DH

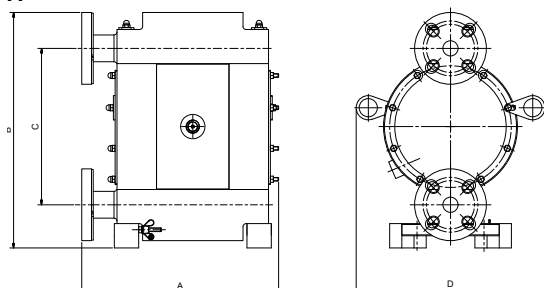

Type	Dimensions mm			
	A	B	C	D
DH 15	260	290	178	-
DH 25	324	387	257	310
DH 40	414	463	307	328
DH 50	559	585	414	-

Stainless Steel Pumps Series L Overview



Series L pumps are made of high-gloss polished stainless steel developed for applications in food, pharmaceutical, cosmetic, and beverage industries.

Our Series L pumps meet relevant industry standards applicable to housing materials (stainless steel), surface quality (up to 0.5 µm), and approved elastomer materials (FDA).

Clean In Place (CIP) and Sterilize in Place (SIP) standards are not uniform throughout the world, and our pumps were designed to take into account regional requirements. Consequently, we have made our pumps available in polished stainless steel 304 or 316L, with high-gloss clamp bands, and as a DH-UE version in a flanged construction design.

By using a large ball valve clearance, our pumps can handle media containing solids, such as pieces of fruit, meat or vegetable, without suffering damage.

Pumps can be supplied with connections for fluids, such as DIN11851, DIN 11864, Triclamp, Neumo or SMS, as required by the application. Some models are supplied with a height-adjustable bright polished frame.

Type	DL 15 (½")	DL 25 (1")	DL 40 (1 ½")	DL 50 (2")	DL 80 (3")
DL-SFS - Cast Stainless Steel 316L Electro Polished	-	●	●	●	●
DL-SF - Cast Stainless Steel 316 L Electro Polished	-	● ¹⁾	● ¹⁾	● ¹⁾	● ¹⁾
DL-SLV - Stainless Steel 304 Polished	-	●	●	●	●
DL-SUV - Stainless Steel 316 L Polished	-	●	●	●	-
DL-UEV - Stainless Steel 316 L, Ra<0,8µm Electro Polished	-	●	●	●	●
DH-UEV - Stainless Steel 316 L1, Ra<0,8µm Electro Polished (Flanged Design)	-	●	●	●	-

1) Not intended for use in highly critical hygienic applications, without CIP and/or SIP.

Type DH-UEV

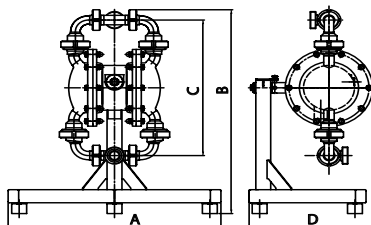

Type DL-SLV

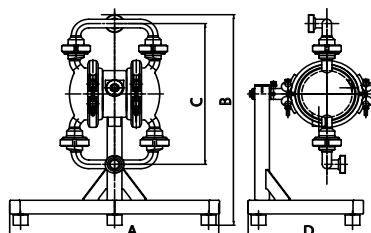

Type	Dimensions mm			
	A	B	C	D
DH 25	571	624	415	332
DH 40	571	711	575	347
DH 50	834	981	714	487

Type	Dimensions mm			
	A	B	C	D
DL 25	571	618	415	337
DL 40	571	705	575	363
DL 50	834	974	714	495
DL 80	834	1063	857	540

Special Design Pumps Series DP Overview



DEPA® Air-Operated Double Diaphragm Pumps type DP can transfer easy-to-fluidize powders economically, in a virtually dust-free and smooth process.

In many industrial applications, powder pumps are used for rapid displacement of contents from vehicles or reusable containers, especially where transfer time and imminent mobility of vehicles/containers impact operating costs.

Our DP 125 is known to be the world's largest air-operated diaphragm pump, and it was developed in cooperation with industry. This pump has been successfully deployed over several years in special applications, providing high capacity transfer of powder.

For gentle transfer of powder the pumps are, depending on type, equipped with a Y-shaped suction and discharge manifolds as standard, in order to significantly improve powder flow. DP pumps are equipped with an additional aeration valve on the suction side inlet to enable finely controlled regulation of the required vacuum. They may also be equipped with a complete fluidization capability.

Main applications: Manufacturing of plastic products, Basic chemistry, Pharmaceutical industry, Breweries, Food industry

Type	DP 25 (1")	DP 40 (1 ½")	DP 50 (2")	DP 80 (3")	DP 125 (5")
FA - Aluminium	●	●	●	●	●
CX - Nodular Cast Iron	-	-	●	●	-
SLV - Stainless Steel 304	-	-	●	●	-

Type DP

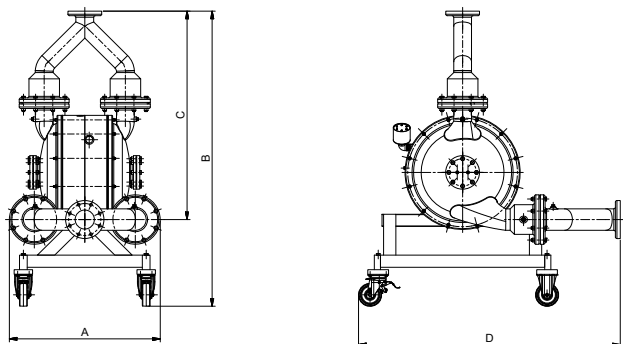

Type	Dimensions mm			
	A	B	C	D
DP 25 - FA	242	437	372	246
DP 40 - FA/CX	311	571	499	255
DP 50 - FA/CX	410	658	570	340
DP 80 - FA/CX	510	813	708	420
DP125 - FA	983	1940	1370	1705
DP 50 - SLV	834	1143	917	564
DP 80 - SLV	834	1248	1096	617

Special Design Pumps Series DF Overview



DEPA® Air-Operated Double Diaphragm Pumps type DF are designed for emptying drums and containers, and provide an economical and wear resistant alternative to other pumping systems.

In order to handle a wide range of fluids, DF 25 pumps are available in alternate housing material options (e.g. aluminium, and stainless steel).

The pump can be quickly and easily mounted on the drum using our (required) drum adapter that is supplied with the pump.

Drums can be completely emptied with the supplied suction pipe. All DEPA® pumps are resistant against damage due to dry running, and are "infinitely" adjustable within their performance range.

Many drum pumps can be combined with DEPA® special accessories and are used by industry for dosing or as filling stations.

Main applications: Chemical industry, Waste disposal technology, Automobile industry, Furniture industry, Heavy industry

Type	DF 15 (½")	DF 25 (1")	DF 40 (1 ½")	DF 50 (2")	DF 80 (3")
FA - Aluminium	-	●	-	-	-
SA - Stainless Steel 316 L	-	●	-	-	-
SX - Stainless Steel 316 L	-	●	-	-	-
SS - Stainless Steel 316 L	-	●	-	-	-

Type DF

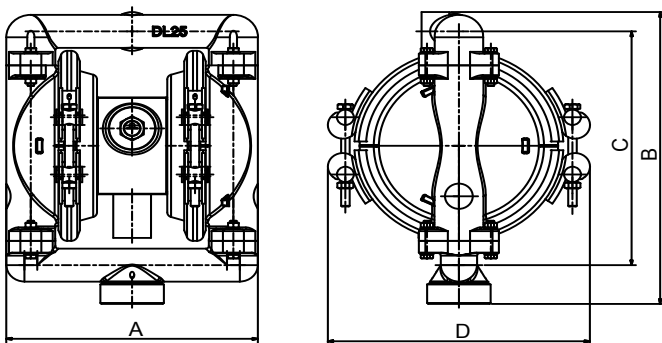

Type	Dimensions mm			
	A	B	C	D
DF 25	236	301	281	246

Accessories Performance

Pulsation Damper

Air operated double diaphragm pumps produce a naturally pulsating flow, which, in some applications, may not be acceptable such as flow metering or fixed pipework. If this is the case then the installation of a Pulsation Damper is recommended. The device is installed directly downstream of the discharge port of the pump which acts against the air cushion in the Damper providing a uniform flow. The DEPA Pulsation Dampers come in two versions: active and passive.

Benefits

- 1 **Excellent damping effect – up to 95% of pulse is removed from the flow path**
- 2 **Simple in line installation**
- 3 **Protects pipelines from unnecessary vibration**

Active Pulsation Dampers

These Dampers are connected to the compressed air supply feeding the pump so their operation is fully automatic, even under variable working conditions. They adjust automatically to variations in pumping pressure or air supply pressure and are suitable for CIP operation.

Passive Pulsation Dampers

These Dampers are not connected to the air supply feeding the pump. They are delivered with a pre charge pressure set depending on the specific application requirements. This pressure can be adjusted to allow use with changing application requirements.



High Performance Muffler

The DEPA High Performance Muffler is available for sizes and materials of DEPA pumps 25, 40, 50 & 80 and can replace the regular muffler supplied as standard with the pumps. The DEPA HPM provides a significant reduction in dBa noise levels when compared to our standard muffler. The HPM, therefore, can provide a significant health & safety benefit in enclosed areas, in areas where many pumps are operating simultaneously or close to where employees are working, thus creating an improved work environment.

- 1 **Reduces noise level benefiting a quieter work environment**
- 2 **Reduces the risk of pump exhaust icing up due to an improved reduction of air velocity**
- 3 **Can be cleaned on site (re-useable)**

Accessories Monitoring

Fluid Level Control

The fluid level control switches the pressurized air supply automatically on or off depending on the fluid level, allowing for independent operator-free operation, therefore eliminating the risk of a pump continuing to run after the fluid has been transferred which will reduce air consumption/ energy costs and increase the life of the wearing parts of the pump. The fluid level control in combination with full cast stainless steel

pumps deliver superior resistance to corrosive chemicals such as alkalines, acids and solvents, thus ensuring reduced maintenance and longer service life.

The mounting of the fluid level control can be separate or fixed to the pump.

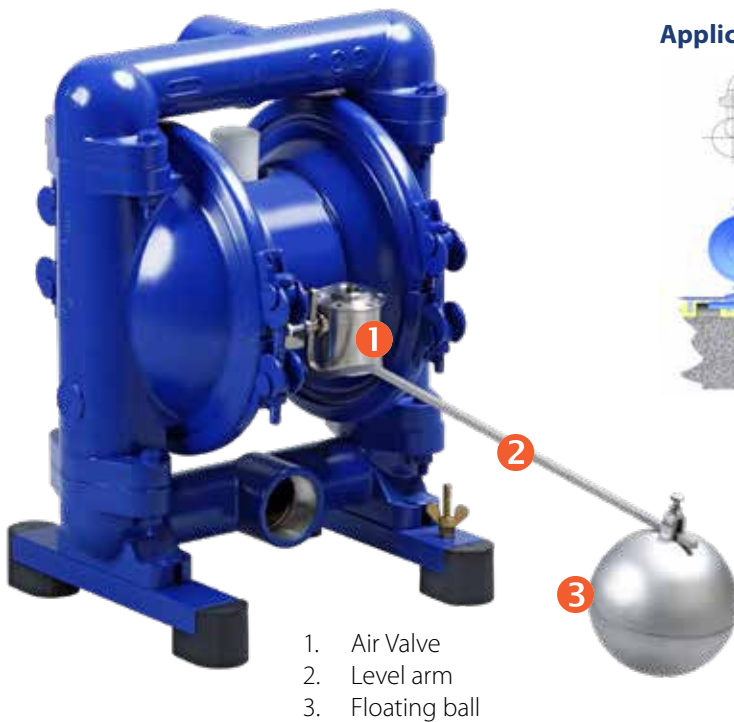

Application Example

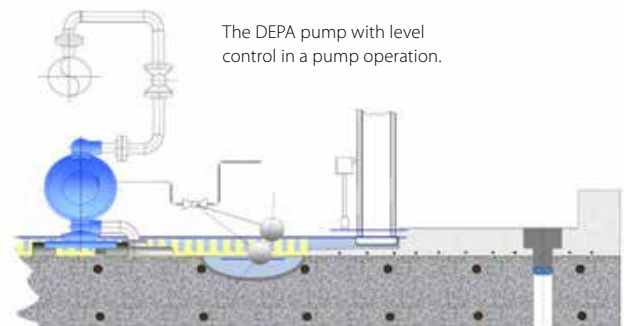

- ❶ Autonomous on/off switch
- ❷ Reduced energy costs
- ❸ Extended Service Life

Air Service Unit For Compressed Air Supply/ Maintenance Unit for Compressed Air

A very useful and important accessory for all air operated diaphragm pumps and active pulsation dampers. The DEPA maintenance unit for the compressed air supply consists of all of the following components: An air filter to remove particles from the air supply larger than 5µm, therefore protecting the wearing parts on the air side of the pump giving longer life between services. A moisture reservoir where any moisture in the air supply is collected and can be drained further protecting the air side of the pump. A needle valve which can accurately adjust the air volume (not air pressure) entering the pump therefore allowing for accurate flow control down to very low levels. The needle valve is installed after the air, filter & regulator unit and is also available as a separate item. An air regulator that allows the air pressure to be adjusted and set to the required

pressure level. The supplied manometer displays the set pressure. Air fittings at both ends to allow easy connection to the compressed air supply.

- ❶ Regulating of pressure
- ❷ Drainage function
- ❸ Speed regulation



Accessories Monitoring

Stroke Counter

The Stroke Counter allows your DEPA diaphragm pump to be used for dosing applications by accurately measuring the number of diaphragm strokes.

The system consist of the Stroke Counter Sensor, the Stroke Counter Evaluation Unit and Amplifier Unit.

The Stroke Counter Sensor is mounted within the air chamber of the pump and can be used in ATEX certified pumps. For the correct read out of the signals from the Stroke Counter Sensor an evaluation unit is required.

The Stroke Counter Sensor monitors each stroke of the diaphragm. In combination with the pump chamber displacement volume, the volume can be exactly determined. The number of strokes can be set in the Stroke counter control. Once the set number of strokes has been reached, the output signal can be used to activate the solenoid valve to switch off the air supply to the pump.



Diaphragm leakage sensors

The Diaphragm Leakage Sensor detects whether fluid has entered the air chamber, because of a diaphragm failure, and stops the pump.

The system consist of two leakage sensors, one for each air chamber, and the Leakage Sensor Amplifier Unit.

The Diaphragm leakage Sensors mounted within the air chamber of the pump and can be used in ATEX certified pumps. The Amplifier Unit placed outside the ATEX area.

The triggered sensor (conductive or capacitive) transmits the signal to the Amplifier Unit. The conductive sensor (orange cable) is used in combination with conductive fluids, whereas the capacitive sensor (blue cable) is used for non-electrically conductive fluids. The output signal from the Amplifier Unit can be used to activate the solenoid valve which interim switches off the air supply to the pump.



- 1 Safety
- 2 Environment protection
- 3 Cost savings

Accessories Test Rig

After maintaining a DEPA® AODD pump, the pressure test verifies leakage tightness of the pump. The test rig ensures safe and hazard-free pressure testing by means of a robust frame design with safety window, pressure limitation valves, safety couplings and an emergency stop. Testing can be conducted on all DEPA® pump sizes (up to size 80).

Product Features

- Robust frame design with pivoting safety window
- Corrosion-free polyethylene water basin
- Emergency stop
- Adjustable air pressure regulator / air limitation valve
- Water - safety coupling
- Discharge manometer
- Ball valves for air supply & water discharge pipe

- 1 Hydrostatic pressure testing
- 2 Operator safety
- 3 For all DEPA Pumps

Weight

- 41 kg (without water)

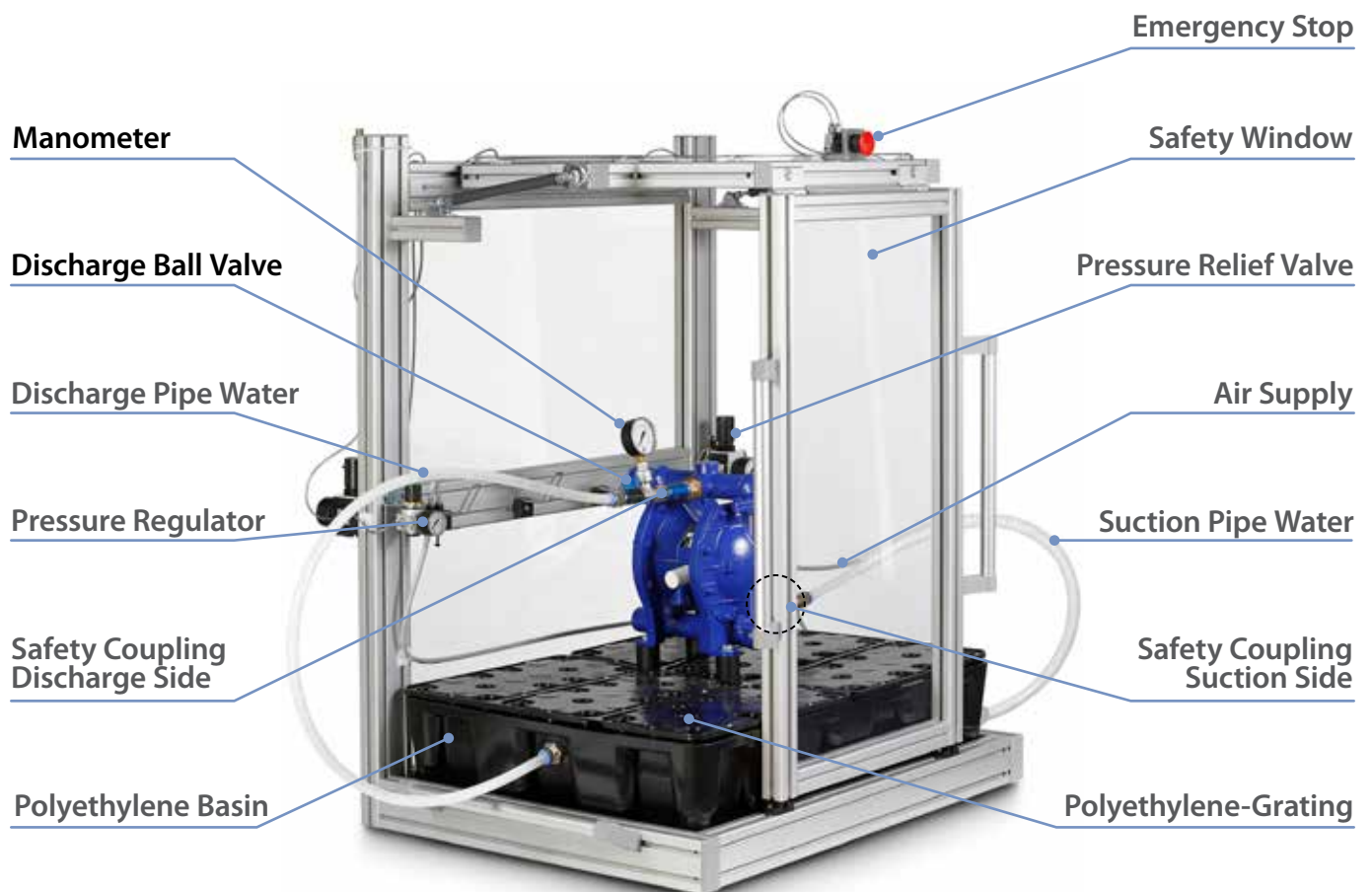

Accessories

Suction & Discharge Connections and Couplings

Suction & Discharge Hose

DEPA Pumps can be fitted with suitable suction and discharge hoses. These are available in nominal sizes ranging from 1" to 4" diameter. They can be connected with "quick couplings" (or other accessories). All hoses are pressure tested. The product range includes standard spiral hoses with plastic or steel reinforcement, hoses for chemical applications, and hoses approved for food applications.



Suction lance (Steel)

DEPA Pumps can be fitted with a suction hose and various types of suction lances for pump sizes 40, 50 and 80 (additional adapter might be required), to handle liquids or powders. Suction lances for liquids are available with and without ball valve made from stainless steel. For powder applications the suction lance comes with an integrated fluidization option. In addition to these standard types of suction lances, a flexible suction lance with different suction nozzles caters for customer specific demands.



Suction strainer

With the suction strainer, the size of the strainer is optimized to stop solids, which could damage your pump!

Protects your DEPA pumps, increase lifetime and reduce costs at the same time. When the strainer is directly mounted on the suction manifold, you can use your DEPA pump as a submersible pump. In this case, the muffler must be mounted outside of the media. Alternatively, you can also mount the strainer on the end of a suction-hose to provide protection of the pump in a standard application.

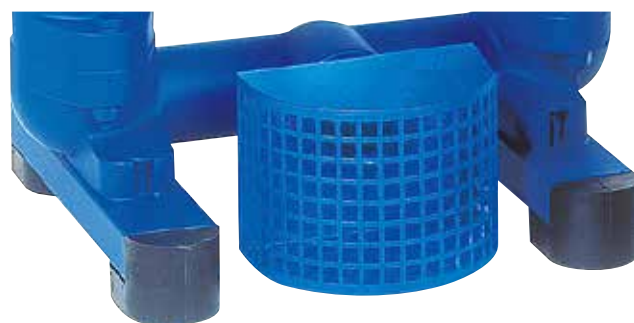

Accessories

Pump Emptying Systems

Valve ball lifter

Innovative design enables in-place drainage for residue-free operation in critical applications such as paint & varnish, storage tanks and filling machines. A dual-rotating pin ensures flawless operation in both clockwise and counter-clockwise direction, eliminating the challenges associated with sticking caused by media remaining in the pump housing. Design in combination with 316L stainless steel delivers superior resistance to corrosive chemicals such as alkalis, acids and solvents, thus ensuring reduced maintenance and longer service life.

- ❶ Drainage in Place
- ❷ Ease of Operation
- ❸ Extended Service Life



Self Drainage System

In-place drainage feature removes the need for additional handling or the de-installation of pump or equipment. The Self drainage system has no impact to max. flow rate and air consumption. The automatic in-line drainage eliminates the need to disconnect the pump, reliable performance reduces the need for additional electronic monitoring, thus reducing operating costs.

- ❶ Automatic in-line drainage
- ❷ Efficient design
- ❸ Reliable performance



Accessories

Air Supply Control

2/2 Solenoid valve

This normally closed diaphragm valve is used for easy ON/OFF steering of your DEPA pump. A simple electrical signal is sufficient to operate the solenoid valve (even in ATEX areas). A typical use of this valve would be in combination with the diaphragm leakage monitoring system to cut off the pump when an incident occurs.

This 2/2 way solenoid valve is in Brass/NBR, PN10 and available for different voltage. The valve has to be connected by cable plug (DIN EN 175301-803, Form A)



External 5/2 or 5/3 solenoid air valve

Sometimes you would like to control each stroke.

We can use a 5/2 solenoid valve to operate each stroke of the DEPA pump. Alternatingly the valve will distribute air to the different air chambers, allowing us to control each pumping movement. The 5/2 would need to be used in combination with an external device (like a switch generator) to get the operating signal.



Accessories

Air Supply Control

Slow Start-up-valve

- The Slow Start-up valve offers low wear for all Air Operated Diaphragm Pumps!
- Significantly reduces the stresses on the diaphragms, pump & system at start up therefore increasing diaphragm life & protecting the pump installation from excess pressure surges.

To have a smooth start-up operation and to avoid sudden pressure loads on the AODD pump, the pump can be equipped with a slow start-up valve. The pressure ramp-up can be adjusted (between a 2 to 10 second control time).



Integrated fluidization system for Powder Applications

Prevents the risk of blocking of the powder in the pump.

DEPA Powder pumps can be fitted with an adjustable air fluidization system in order to ventilate the pump chambers to assist the movement of powder through the pump to reduce the risk of powder 'packing out' in the pump and causing a blockage. This can be done prior to the starting of the pump, or supporting during pumping operation.

To further improve the flow of powder through the system it is recommended to have adequate radii of elbows in the pipelines or hoses. The powder pump manifolds are shaped in Y-form to prevent unnecessary obstacles.

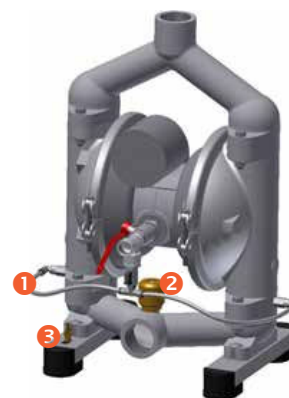

- 1 Integrated fluidization system
- 2 Spring-loaded air valve (air from environment)
- 3 Earthing screw

Operation

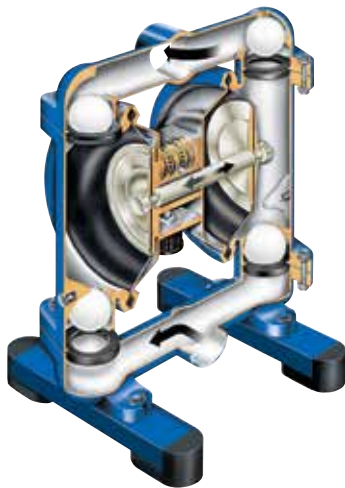

Operation

DEPA® Air-Operated Double Diaphragm Pumps work on the principle of oscillating positive displacement, with two back-to-back pump chambers. Both are divided by a diaphragm into an air and a fluid region. The two diaphragms are connected by a piston rod, creating the effect that during one cycle medium is expressed out of one pump chamber while medium is being drawn into the other pump chamber. The four drawings depict the sequence of a complete cycle consisting of suction and pressure strokes, showing an empty and a "full" air-operated diaphragm pump. The medium is presented in colour (red/green), for ease of demonstration.

- red = medium in suction condition
- green = medium in discharge condition

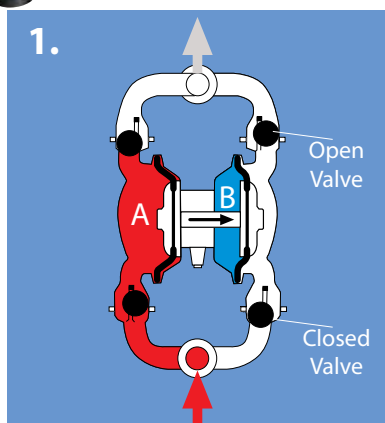

1. On start-up, pressurized air in region B (acting via connected diaphragms) lowers the pressure in chamber A.

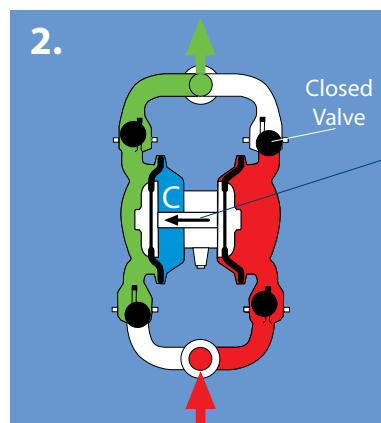

2. Pressurized air in region C acts on the diaphragm to displace product out of the pump.

End positions of inner pistons switch the control valve between alternating phases.

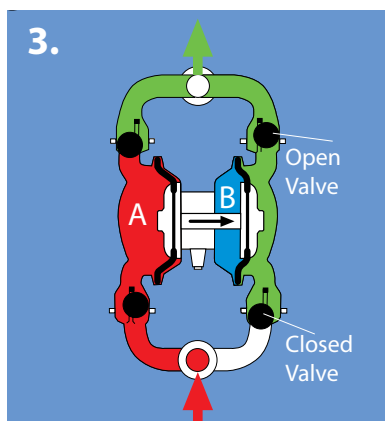

3. The process continues by again creating pressure in region B, this time expelling product from the pump while drawing in new product into chamber A where simultaneously a low pressure had been generated.

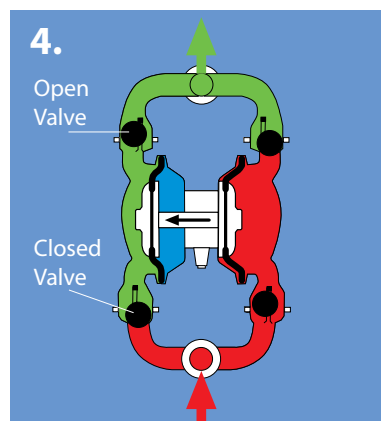

4. The cycle repeats by alternately producing pressure in regions B and C while the pump is in operation.

Selection

Selection

To select the right DEPA® pump for your application, the following factors should be considered to achieve economy of operation, long pump life, and minimal maintenance costs:

- The nature of the medium to be pumped, its viscosity, and the solids content (proportion to total content)
- Pumping capacity in relation to the desired output (per unit of time)
- Suction and pressure conditions

Considering these parameters, an optimal pump size is selected when the intersection of the intended installation "pressure vs. flow rate" is near the middle section of the curves. Please contact your Crane DEPA® representative for assistance in specifying Special Design pumps.

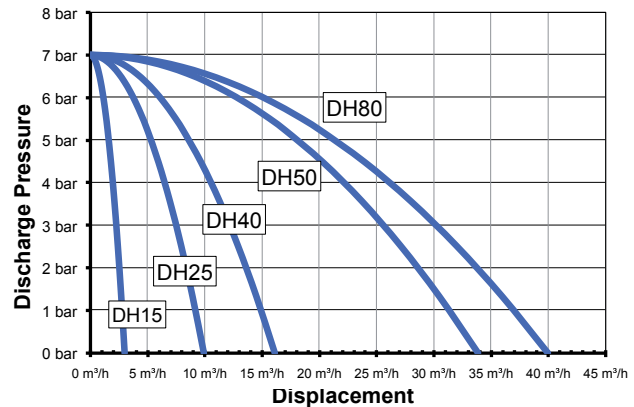

The graph is for orientation purposes only.

Capacities with Specified Suction Lift

All DEPA® Air-Operated Double Diaphragm Pumps are self-priming. There is a difference between "dry" (without medium) and "wet" (with medium) priming. When calculating the pumping capacity, the specific gravity of the product and the respective suction lift must be taken into consideration. Furthermore, losses attributed to piping or hoses on the suction side and the specific properties of housing and diaphragm materials must also be factored in.

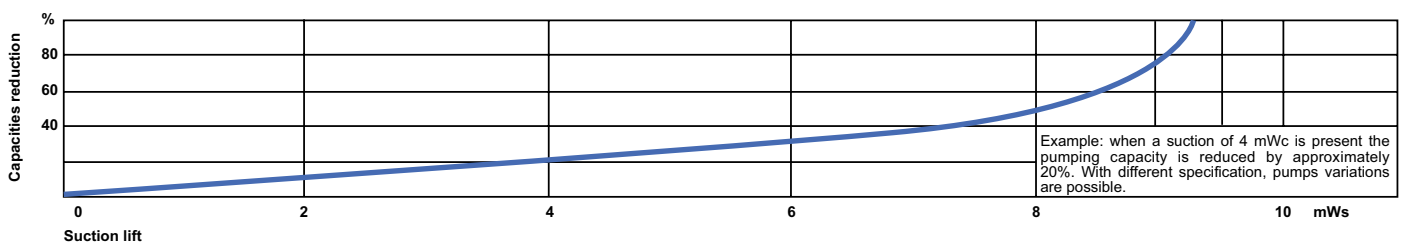

Capacities with Viscous Fluids

All capacity curves shown in the diagram are related to water (1 mPa·s). In order to determine the appropriate pump capacity for viscous media, the realized capacity reductions shown in the diagram must be considered in relation to the known viscosity. In addition, factors such as product flow properties, length and cross-section of piping or hoses on suction and discharge sides, and valve and pump sizes with their specific characteristics must be taken into account.

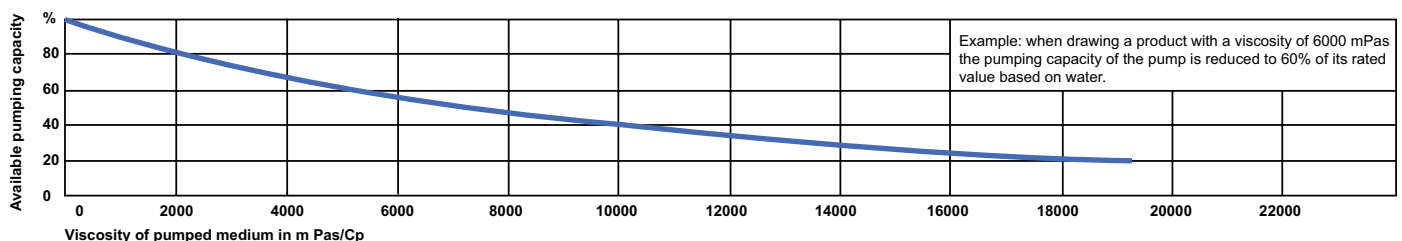

Installation Overview

Installation

DEPA® Air-Operated Double Diaphragm Pumps are suitable for an endless variety of applications and are not restricted to only certain industries or processes. Our pumps can be deployed in stationary (fixed) installations within a process flow system, or used as portable or mobile units that can be transported to where it is to be used.

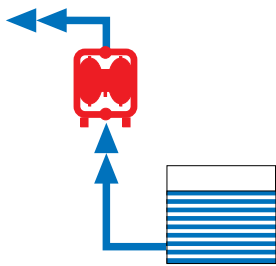

Self-priming pump

DEPA® Air-Operated Double Diaphragm Pumps are dry self-priming. Depending on the pump specification a suction lift of up to 9 mWC can be achieved with a filled suction pipe.

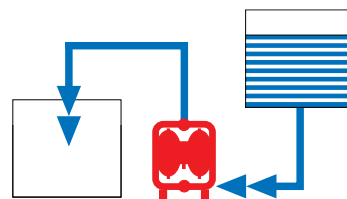

Pump with positive suction

Depending on the pump type, the suction side inlet pressure may need to be limited to a max. pressure 0.7 bar. In such cases a valve is required to isolate the suction pipe.

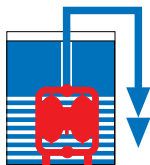

Sub merged pump

DEPA® Air-Operated Double Diaphragm Pumps can be totally submerged in the pumped medium. The chemical compatibility of the pump material must be checked beforehand. The exhaust outlet must remain above the fluid level.

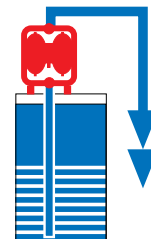

Pump for drums

DEPA® Air-Operated Double Diaphragm Pumps of type DF 25 can be directly mounted on drums or containers. For ease of use the pump is mounted on the container complete with adapter. The suction pipe is supplied with the pump.

Air-Operated Double Diaphragm Pumps Key Features:

- gentle conveyance of liquid or viscous products
- ideal for abrasive, viscous, and shear sensitive media
- can handle media with entrained solids
- tolerant of dry running
- no dynamic or pressure loaded seals
- mobile, easy to transport units
- infinite regulation of pumping capacity
- dry self-priming
- can run against closed valves
- modern compressed air control, low maintenance
- submersible designs
- also suitable for use in explosive and hazardous areas
- operation and maintenance friendly

Notes

DEPA®

Crane ChemPharma & Energy

Crane Process Flow Technologies GmbH

Postfach 11 12 40, D-40512 Düsseldorf

Heerdter Lohweg 63-71, D-40549 Düsseldorf

Tel.: +49 211 5956-0

Fax.: +49 211 5956-111

www.cranecpe.com

www.depapumps.com

CRANE®

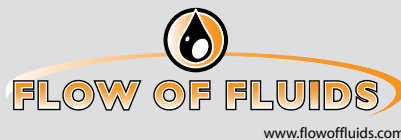

brands you trust.



CPE-DEPA-OVERVIEW-BU-EN-A4-2020_01_31

Crane Co., and its subsidiaries cannot accept responsibility for possible errors in catalogues, brochures, other printed materials, and website information. Crane Co. reserves the right to alter its products without notice, including products already on order provided that such alteration can be made without changes being necessary in specifications already agreed. All trademarks in this material are property of the Crane Co. or its subsidiaries. The Crane and Crane brands logotype, in alphabetical order, (ALOYCO®, CENTER LINE®, COMPAC-NOZ®, CRANE®, DEPA®, DUO-CHEK®, ELRO®, FLOWSEAL®, JENKINS®, KROMBACH®, NOZ-CHEK®, PACIFIC VALVES®, RESISTOFLEX®, REVO®, SAUNDERS®, STOCKHAM®, TRIANGLE®, UNI-CHEK®, WTA®, and XOMOX®) are registered trademarks of Crane Co. All rights reserved.